

Tapa
CUE 1

xc.

(lunga)

3

3.2

S. *p* Or-de — r

A. *p* Or-de — r

T. *p* Or-de — r

B. *p* Or-de — r

(lunga)

10rus

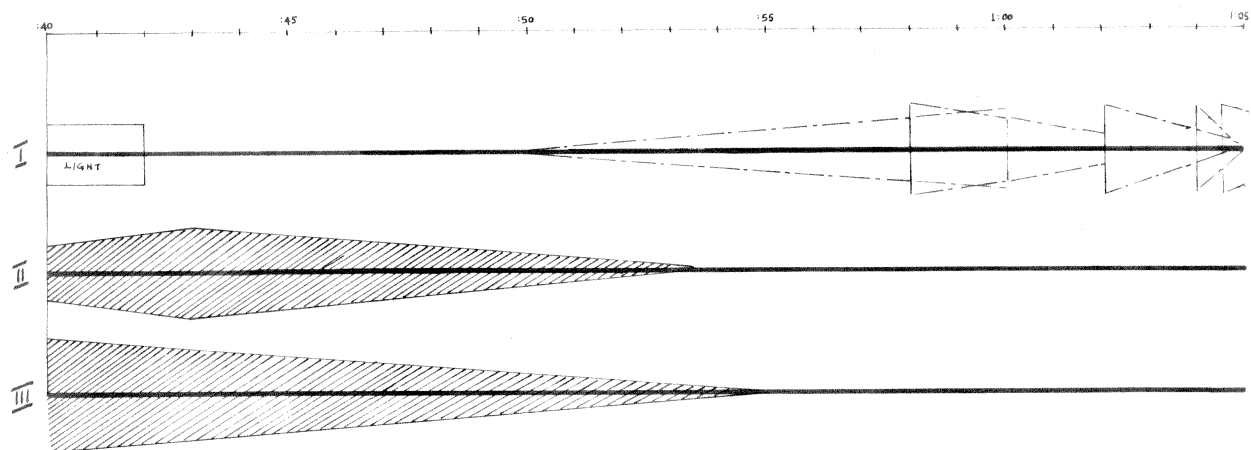
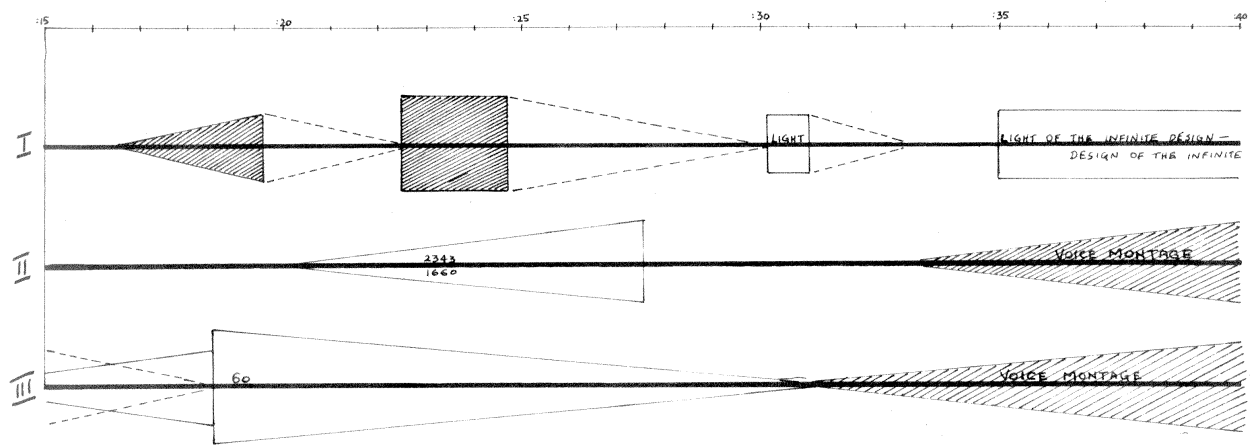

D

Tempo un po' agitato (♩ = 60 circa)

poco rall.

2 *senza sord.* *fff ten* #0 *f* *p* (pause)

4 *senza sord.* #0 #0

1 *senza sord.* #0 #0

2 *senza sord.* #0 #0

1 *senza sord.* #0 #0

2 *senza sord.* #0 #0

1 *senza sord.* #0 #0

2 *senza sord.* #0 #0

JETSTREAMS IN UPPER WINDS - BLOOD - THE TRAIL OF GALAXIES - STAR - DRIFT - ANTS

B.D. 3 2

Bonitos (hard stroke) *ff*

S.D. > (snare off) *mf*

mf *p*

* div. a 2 1/4 tone tuning

* div. a 2 1/4 tone tuning

* div. a 2 1/4 tone tuning

* div. a 2 1/4 tone tuning

* div. a 2 1/4 tone tuning

* div. a 2 1/4 tone tuning

* div. a 2 1/4 tone tuning

rall

Speaker

MISTS AND WATERS - NOOKS AND CRANNIES OF THE SEA

(quieter)

Q

BREATH - THE AWFUL SPACE OF SILENCE

6

4

Harp

Vibra

soft sticks

ppp (senza ped)

ped (norma vibrato)

f

mf

(laissez vibr.)

G.P.

Perc.

TRIANGLE

G.P.

Timp.

Viols I
II

Violas

Celli

Bass

f

fp

6:4

G.P.